



Color/B&W Duplex Multiplexer MP/BMP400

USER'S MANUAL



Safety Precautions

TO PREVENT FIRE OR ELECTRIC SHOCK, DO NOT EXPOSE THIS PRODUCT TO RAIN OR MOISTURE.

	CAUTION RISK OF ELECTRIC SHOCK DO NOT OPEN	
CAUTION: TO REDUCE THE RISK OF ELECTRIC SHOCK, DO NOT REMOVE COVER (OR BACK). NO USER-SERVICEABLE PARTS INSIDE. REFER SERVICING TO QUALIFIED SERVICE PERSONNEL.		

ATTENTION:
POUR EVITER LES CHOCS ELECTRIQUES, INTRODUIRE LA LAME LA PLUS LARGE DE LA FICHE DANS LA BORNE CORRESPONDANTE DE LA PRISE ET POUSSER JUSQU'AU FOND.



This symbol is intended to alert the user to the presence of uninsulated “dangerous voltage” within the product’s enclosure that may be of sufficient magnitude to constitute a risk of electric shock to persons.



This symbol is intended to alert the user to the presence of important operating and maintenance (servicing) instructions in the literature accompanying the appliance.

Operating Safety

- ?? Use only the factory supplied (5VDC 8.0A) power adapter to operate the system.
- ?? Do not try to force the system’s plug into a power outlet. It has one blade that is wider than the other for safety purposes.
- ?? If any liquid or solid object falls into the cabinet, unplug the system and have it checked by a qualified technician before operating it again.
- ?? Do not block the ventilation opening. The openings keep the system from overheating.
- ?? Do not install the system in a hot or humid place, or where there is excessive dust or vibration.

Owner’s Record

The model and serial numbers are located at the bottom of the system. Record these numbers in the spaces provided below. Refer to them whenever you call technical support regarding this product.

Model Number: _____

Serial Number: _____

FCC Compliance Statement

User/installer Caution: Your authority to operate this FCC verified equipment could be voided if you make changes or modifications not expressly approved by the party responsible for compliance to Part 15 of the FCC rules.

This digital apparatus does not exceed the Class A limit for radio noise emissions from digital apparatus set out in the radio interference regulations of Canada.

Note: this equipment has been tested and found to comply with the limits for a Class A digital device, pursuant to Part 15 of the FCC rules. These limits are designed to provide reasonable protection against harmful interference when the equipment is operated in a commercial environment. This equipment generates, uses, and can radiate radio frequency energy and if not installed and used in accordance with the instruction manual, may cause harmful interference to radio communications. Operation of this equipment in a residential area is likely to cause harmful interference that the user will be required to correct at his or her own expense.

Contents

Safety Precautions	1
FCC Compliance Statement	2
Panel Controls and Connectors	4
Front Panel Controls	4
Back Panel Connectors	5
Basics System Setup	6
Basics Operations	7
Full Screen / Split-Screen Modes	7
Video Switching Mode	8
VCR Playback Mode	9
Call Monitor	10
System Setup Menu	11
Understanding Menu Buttons	12
Main Menu	13
Dwell Time	14
Display Formats	15
Alarm Settings	19
Activity Detection	20
Display – Date & Time Settings	21
Clock / Camera ID	22
Advanced Configuration	23
Options	23
Event Log & Factory Default	24
VCR Playback	25
Bypass Mode	26
Tracking Adjustment	27
Alarm Setup	28
Remote Interface	30
Command Set	31
Specifications	32

Panel Controls and Connectors

Front Panel Controls

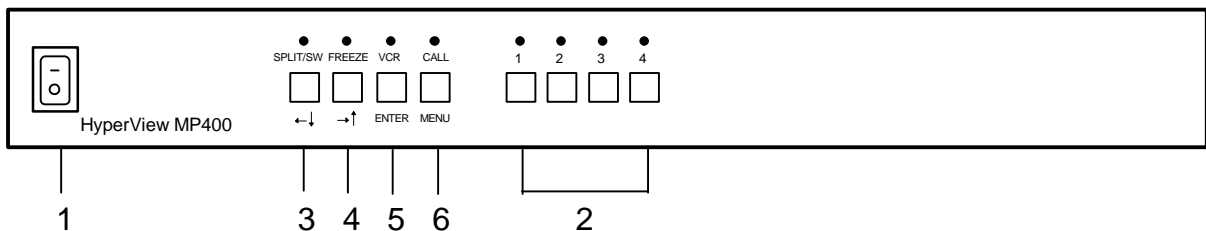

- 1. Power Switch p. 7**
Turns the MP/BMP400 on and off.
- 2. Video Selector p. 7**
Selects a camera input to be displayed in full-screen mode to the main monitor output.
- 3. SPLIT/SW Selector p. 7**
Selects a preset multi-screen mode and the multi-screen/full-screen switching mode's main monitor output.
←↓ Function p. 12
The SPLIT/SW button provides down and left navigation while in user setup mode.
- 4. FREEZE Button**
Freezes the currently selected video input's main monitor output or returns to normal video.
→↑ Function p. 12
The FREEZE button provides up and right navigation while in user setup mode.
- 5. VCR Button p. 9**
Selects a VCR input to be displayed to main monitor output. This button does not affect the VCR output during duplex operation.
ENTER Function p. 12
The PLAYBACK button acts as the ENTER button while in user setup mode.
- 6. CALL Button p. 10**
If this pressed for less than three seconds, this button will enable or disable call monitor select mode.
MENU Function p. 11
If pressed for longer than three seconds, the MP/BMP400 will enter user setup mode.

Panel Controls and Connectors

Back Panel Connectors

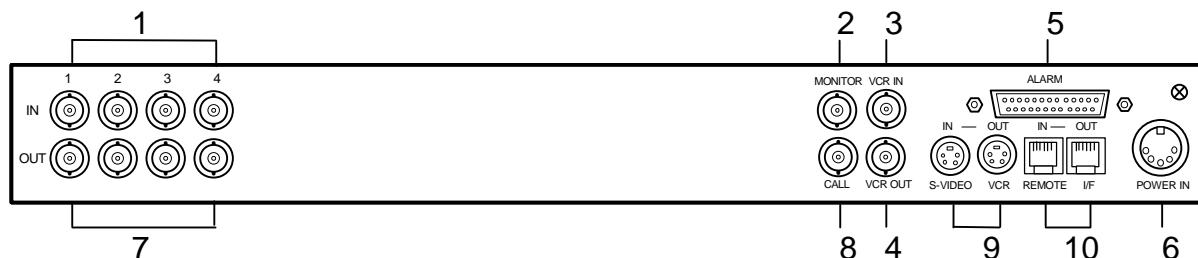

1. Video Input

Connects to the video output of up to 4 cameras.

2. Main Monitor Output

Connects to the video input of a video monitor.

3. VCR Input

Connects to the video output of a VCR or time lapse recorder.

4. VCR Output

Connects to the video input of a VCR or time lapse recorder.

5. Alarm Input/Output

Connects to the alarm input sources and output targets.

6. Power Input

Connects to the factory supplied AC/DC power adapter.

7. Loop Thru Output

Connects to the video inputs of other video systems.

8. Call Monitor Output

Connects to the video input of a secondary video monitor.

9. S-Video VCR Input/Output

Connects to S-Video output/input of a S-Video VCR or time lapse recorder.

10. Remote Interface Input

Connects to a MP/BMP400 compatible system control device or to a computer using optional IBM PC interface cable.

Basic System Setup

Typical System Configuration Diagram

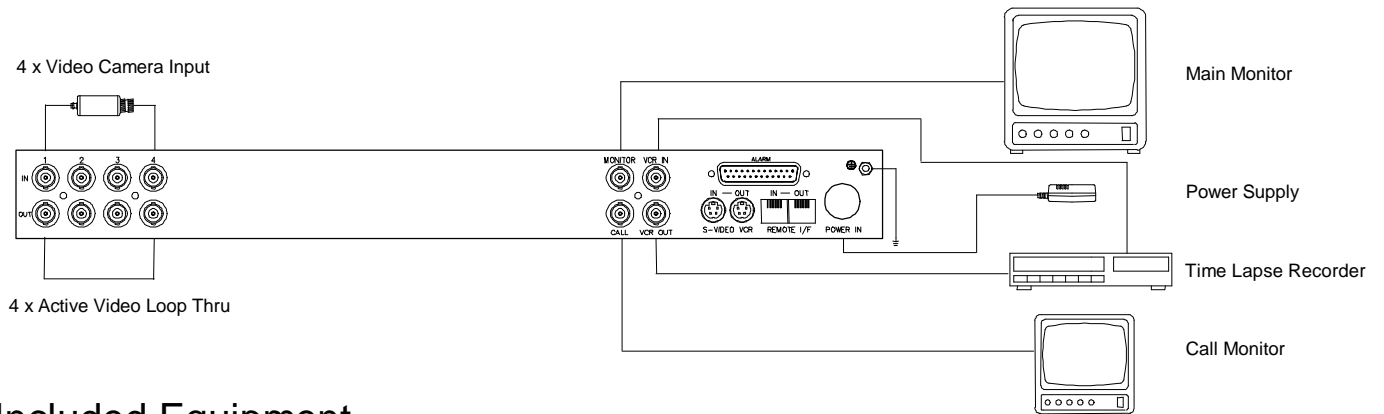

Included Equipment

- ?? Multiplexer Unit
- ?? AC/DC Power Supply
- ?? Operating Instructions
- ?? AC Power Cord

Recommended Equipment

- ?? Video Monitor
- ?? Video Tape Recorder
- ?? Video Cameras
- ?? Coaxial BNC Cables

Configuration

Video Cameras

Connect up to 4 cameras to the 4 video inputs using coaxial cable.

Main Monitor

Connect the main monitor output with the video input connector on a video monitor using coaxial cable.

Call Monitor

Connect the call monitor output with the video input connector on a video monitor using coaxial cable.

Video Tape Recorder

Connect the VCR input with the video output on a VCR or a time-lapse tape recorder using coaxial cable.

Connect the VCR output with the video input on a VCR or a time-lapse tape recorder using coaxial cable.

Power Supply

Make sure the power switch is off before connecting the power supply. Once the power is off, connect the factory supplied AC power supply with the DC plug on the MP/BMP400 and the AC power outlet.

Power Switch

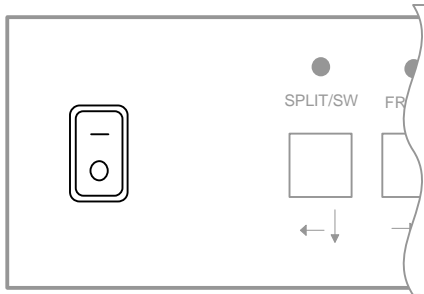

Basic Buttons

Power Switch

Turning Power On

To turn power on, press the top half of the power switch marked “-”.

Turning Power Off

To turn the power off, press the bottom half of the power switch marked “0”.

Caution: Make sure the power switch is set to the off position when connecting the AC/DC adapter to the POWER IN connector on the MP/BMP400 and the AC outlet.

Full-Screen Mode Video Selector

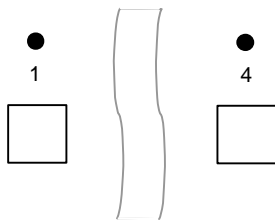

Full-Screen Mode

To select a desired camera input to be displayed, press the button number corresponding to the camera's number. For example, press button 2 to display the input from camera 2 on the main monitor.

SPLIT/SW Button

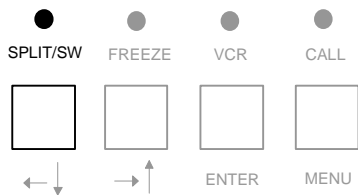

Split-Screen Mode

Press the SPLIT/SW button for less than three seconds from any full-screen or preset-screen mode. p. 15

SPLIT/SW Button

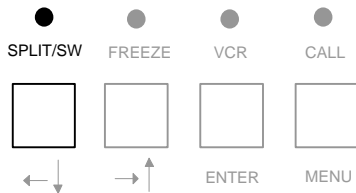

Video Switching Mode

Multiscreen or Full-Screen Switching Mode

Press the SPLIT/SW button for more than three seconds to select switching mode. Pressing the SPLIT/SW button for less than three seconds will activate the split mode.

Activating Full-Screen Switching

Press the SPLIT/SW button while the screen is in full screen.

Activating Preset-Mode Switching

Press the SPLIT/SW button while in any multi-screen mode. Dwell time can be set for A, B, C and D.

*Note: The SPLIT/SW button is a preset-screen selection button. Each time this button is pressed, the system will switch between each preset Mode. Video switch and customized video modes **are not available** in VCR playback mode.*

VCR Button

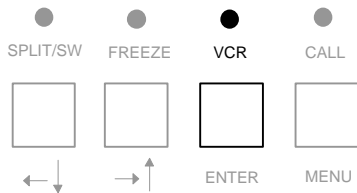

VCR Playback Mode

Entering VCR Playback Mode

Press the VCR button from any video mode to display the VCR input (VCR IN) on the main monitor. The VCR output will remain unchanged.

Returning to Live Mode

Press the VCR button in VCR playback mode to restore the mode prior to VCR playback mode.

Note: Pressing MENU button in VCR playback mode will select a bypass mode (p.26) or tracking adjustment (p.27).

Call Monitor

CALL Button

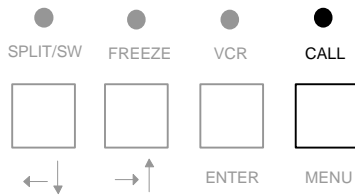

Activating Call Monitor

1. Press the CALL button for less than three seconds to enter call-monitor select mode - a press longer than three seconds will activate the MAIN MENU.
2. The call light will blink to indicate that MP/BMP400 is in the call monitor select mode.
3. Select the desired call monitor by pressing the number of desired camera on the front panel.
4. The light will go off to indicate the completion of the call monitor selection.

When the alarm inputs are enabled and triggered, their corresponding video inputs are displayed to the call monitor. In the event of multiple alarm triggers, the call monitor will switch between video inputs in one-second intervals for the duration defined in user setup menu.

MENU Function

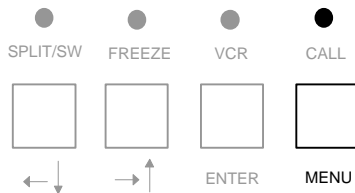

User Setup Mode

User Setup Mode Description

The user setup menu allows for the programming of various system operations from within a menu-based interface. This interface consists of an on-screen menu, a three-button select, and modify operations.

Entering User Setup Menu

Press the MENU button for longer than three seconds from any live video mode to display the main setup menu on screen.

Exiting User Setup Menu

Press the MENU button for longer than three seconds while in the user setup menu to exit the user setup menu.

Note: The alarm will not operate while MP/BMP400 is in user setup mode.

Menu Buttons

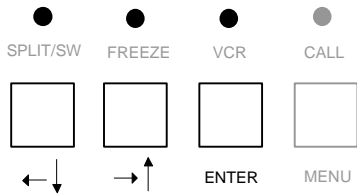

? ? (left /down) Function

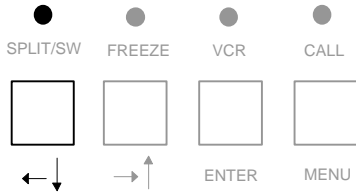

? ? (right/up) Function

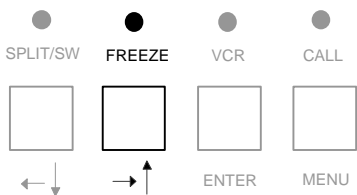

ENTER Function

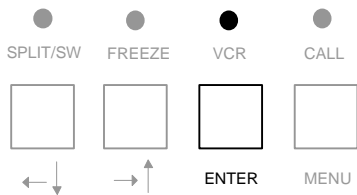

Menu Buttons

The three buttons to the left of the MENU button are used to control the cursors and select items in each menu screen while the MP/BMP400 is in user setup mode. The alternative functions of these three buttons are marked below the buttons as shown on the diagram.

? ? (left /down) Function

This button moves the cursor to the left or down. When an item is selected, this button changes (or decreases) the value of the selected item.

? ? (right/up) Function

This button moves the cursor to the right or up. When an item is selected, this button changes (or increases) the value of the selected item.

ENTER Function

This button selects the item that is currently pointed to by the cursor. If this button is pressed while an item is selected, the current value and setting will be saved. To discard the changes, press the MENU button instead of the ENTER button.

Main Menu

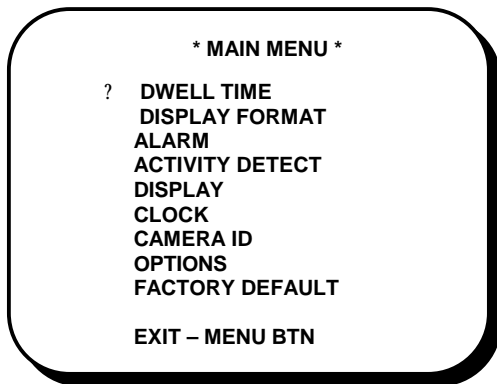

The MAIN MENU is the first screen you will see when MENU button is pressed for longer than three seconds. The currently selected sub-menu is denoted by a “?” “ on the left of the sub-menu item.

Advancing to a Sub-Menu

1. Use the ? ? or ? ? button to move the cursor to the item of interest. The ? ? and ? ? buttons are the SPLIT/SW and FREEZE buttons, respectively, while the MP/BMP400 is in user setup mode.
2. Select the item using the ENTER button. The ENTER button acts as the PLAYBACK button when the MP/BMP400 is in user setup mode.
3. A new sub-menu screen will appear.

Press the MENU button for longer than three seconds to exit the MAIN MENU.

DWELL TIME p.14

Causes the MP/BMP400 to spend a set amount of time on each camera during video switching mode.

DISPLAY FORMAT p.15

Allows configuration of four user configurable split screens.

ALARM p.19

Enables or disables the alarm inputs and configure actions upon alarm trigger.

ACTIVITY DETECT p. 20

Enable, disable, or set up activity detection of each camera input.

DISPLAY p. 21

Allows configuration of the various on-screen displays of the date, time, and camera identification.

CLOCK p. 22

Allows current time and date to be set.

CAMERA ID p. 22

Allows each camera to be given an identification name of up to 12 characters per camera.

OPTIONS p. 23

Allows configuration of various options available on the MP/BMP400.

FACTORY DEFAULT p. 24

Reset all system value to the factory default values.

Dwell Time

DWELL TIME	
CAMERA	TIMER
1	1 SEC
2	1 SEC
3	1 SEC
4	1 SEC

NEW PAGE
RETURN

DWELL TIME	
MODE	TIMER
A	2 SEC
B	2 SEC
C	2 SEC
D	2 SEC

NEXT PAGE
RETURN

The MP/BMP400 is capable of allowing each camera's dwell time to be set independently.

Changing Dwell Time

1. Select DWELL TIME from the MAIN MENU. Move the cursor to the camera whose dwell time is to be changed using the **??** or **??** button. The **??** and **??** buttons are the SPLIT/SW and FREEZE buttons, respectively, while the MP/BMP400 is in user setup mode.
2. Select the camera to be changed using the ENTER button. The PLAYBACK button becomes the ENTER button when the MP/BMP400 is in user setup mode.
3. Press the **??** button to decrease or the **??** button to increase the dwell time to the desired time.
4. Save the setting by pressing the ENTER button.

You may repeat steps two through five above for each camera that requires changes to dwell time.

Preset-Mode Switching

In preset mode, dwell time can be set four different ways and then saved in presets A, B, C and D.

See page 15 for more details on different split-screen modes.

Display Formats

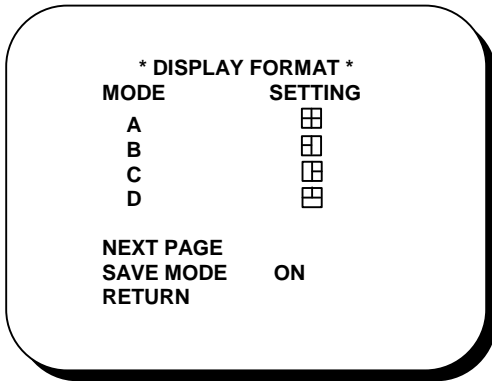

The MP/BMP400 is capable of having four different preset screens configured.

Each mode setting can be configured by the user.





Once you have set up the preset screens, you can select the desired preset screen by pressing SPLIT/SW button.

Display Save Mode

Save mode allows you to save the last screen you were in before turning off the system.

Saving a Mode

1. Select SAVE MODE from DISPLAY FORMAT.
2. Use the ? ? or ? ? button to change the setting to ON or OFF. The ? ? or ? ? buttons are the SPLIT/SW and FREEZE buttons, respectively, while the MP/BMP400 is in user setup mode.
3. Save the setting by pressing the ENTER button. The PLAYBACK button becomes the ENTER button when the MP/BMP400 is in user setup mode.

# DISPLAY FORMAT #	
MODE	SETTING
?? A	
B	
C	
D	

Mode

The numbers represent the preset modes. The four mode settings are broken down into four quadrants (A, B, C and D).

Changing the Mode Setting

1. Using the ?? or ?? button to move the cursor to the mode that is to be changed. The ?? and ?? buttons are the SPLIT/SW and FREEZE buttons, respectively, while the MP/BMP400 is in user setup mode.
2. Select the mode using ENTER button. The ENTER button is the same as the PLAYBACK button when the MP/BMP400 is in user setup mode.

Standard Split-Screen Layouts

2x2

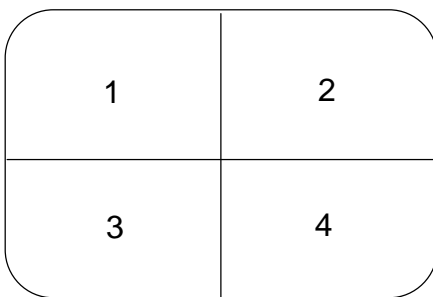

Tri-Mode (A)

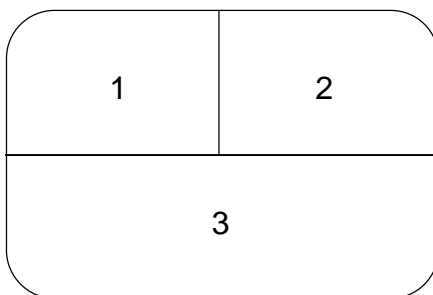

Tri-Mode (B)

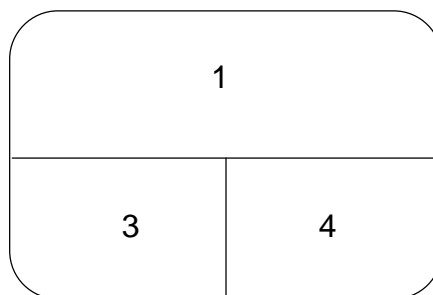

Standard Split-Screen Types

The MP/BMP400 allows the selection and configuration of up to four standards of custom screen display. You may select the desired screen by pressing the SPLIT/SW button, which will allow you to toggle through your four preset screen settings.

2x2 Mode

Four-camera mode allows you to view cameras 1, 2, 3 and 4.

Tri-Mode (A)

Tri-Mode allows you to view cameras 1, 2, and 3 in Tri-Mode (A) mode.

Tri-Mode (B)

Tri-Mode allows you to view cameras 1, 3, and 4 in Tri-Mode (B) mode.

Tri-Mode (C)

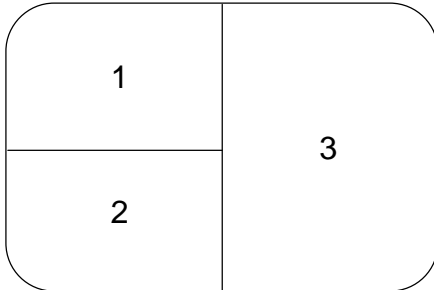

Tri-Mode (C)

Tri-Mode allows you to view cameras 1, 2, and 3 in Tri-Mode (C) mode.

Tri-Mode (D)

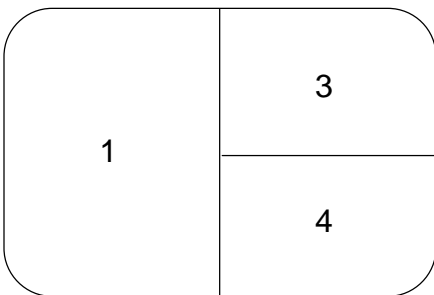

Tri-Mode (D)

Tri-Mode allows you to view cameras 1, 3, and 4 in Tri-Mode (D) mode.

Dual-Mode (A)

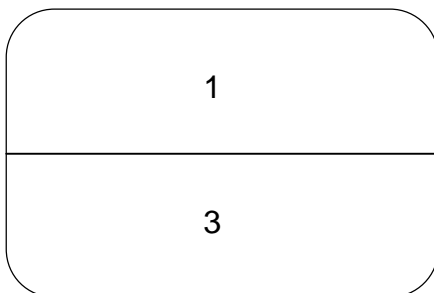

Dual-Mode (A)

Dual-Mode allows you to view cameras 1, and 3 in Dual-Mode (A) mode.

Dual-Mode (B)

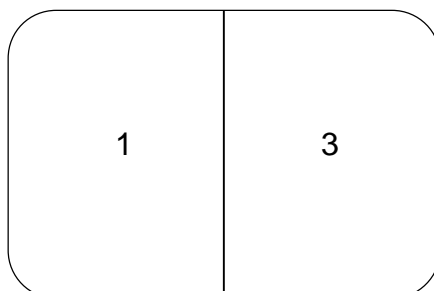

Dual-Mode (B)

Dual-Mode allows you to view cameras 1, and 3 in Dual-Mode (B) mode.

Alarm Settings

* ALARM *	
CAMERA	ALARM
1	OFF
2	OFF
3	OFF
4	OFF
TIME RETURN	15 SEC

Each alarm input to the MP/BMP400 can be configured independently.

Changing Alarm Settings

1. Select ALARM from MAIN MENU.
2. Using ? ? or ? ? button to move the cursor to the camera whose alarm setting is to be changed. The ? ? and ? ? buttons are the SPLIT/SW and FREEZE buttons, respectively, while the MP/BMP400 is in user setup mode.
3. Select the desired camera using the ENTER button. The ENTER button is the same as the PLAYBACK button when the MP/BMP400 is in user setup mode.
4. Press ? ? or ? ? button to change the alarm setting.
5. Save the setting by pressing the ENTER button.

You may repeat steps two through five above for each camera that requires changes to the alarm set up.

Available Alarm Settings

- OFF** Alarm is off, so the MP/BMP400 will not respond to the alarm inputs.
- BEEP** The MP/BMP400 will generate an alarm, a beeping noise, to alert when it is triggered by an alarm input.
- VIDEO** The MP/BMP400 will display a magenta frame around the affected video on both the MAIN MONITOR and the VCR OUT when it is triggered by an alarm input.
- V+B** The MP/BMP400 will sound an alarm, a beeping noise, and display a message on the monitor when it is triggered by an alarm input.

Activity Detection

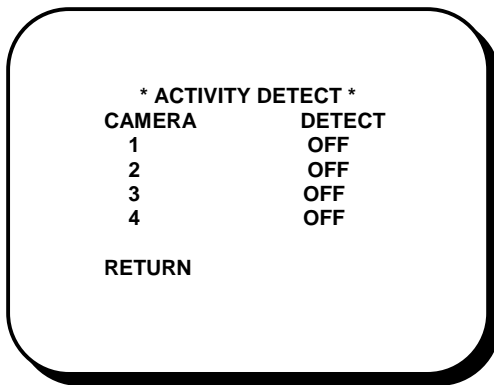

Each alarm input to the MP/BMP400 can be configured independently by changing its respective camera activity detection setting.

Changing Activity Detection Settings

1. Select ACTIVITY DETECT from the MAIN MENU.
2. Using \leftarrow or \rightarrow button to move the cursor to the camera whose activity detection setting is to be changed. The \leftarrow and \rightarrow buttons are the SPLIT/SW and FREEZE buttons, respectively, while the MP/BMP400 is in user setup mode.
3. Select the desired camera using the ENTER button. The ENTER button is the same as the PLAYBACK button when the MP/BMP400 is in user setup mode.
4. Press \uparrow or \downarrow button to change the camera's alarm setting.
5. Save the setting by pressing the ENTER button.

You may repeat steps two through five above for each camera that requires changes to set up an alarm.

Available Detection Settings

OFF

Activity detect is off, so the MP/BMP400 will not respond to any activity.

MIN TO MAX

The lower the number the more movement is required to activate the Activity Detection. Determine the desired setting by experimenting with different degrees of sensitivity.

Note: The alarm setting must be active on the corresponding camera in order for the activity detection to work. For example, if you wish to have an activity detection on camera 1, select the setting under the ACTIVITY DETECT MENU for camera 1 and also select the setting under the ALARM MENU for camera 1.

Display Settings

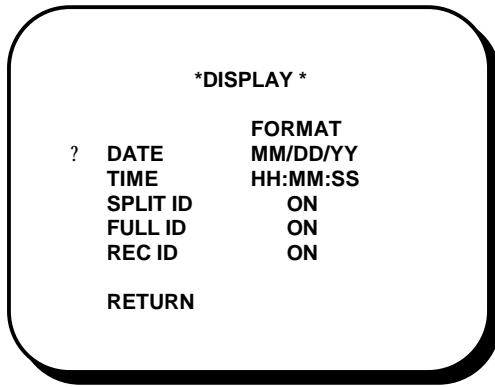

Available Date Settings

OFF	No date information is displayed.
MM/DD/YY	Month/Day/Year
DD/MM/YY	Day/Month/Year
DD/MM	Day/Month

Changing Display Settings

1. Select DISPLAY from the MAIN MENU.
2. Using ? ? or ? ? button to move the cursor to the item whose setting is to be changed. The ? ? and ? ? buttons are the SPLIT/SW and FREEZE buttons, respectively, while the MP/BMP400 is in user setup mode.
3. Select the item using the ENTER button. The ENTER button is the same as the PLAYBACK button when the MP/BMP400 is in user setup mode.
4. Press the ? ? or ? ? button to change the setting.
5. Save the setting by pressing the ENTER button.

Available Time Settings

OFF	No time information is displayed.
HH:MM	Hour:Minute
HH:MM:SS	Hour:Minute:Second
SPLIT ID	Enable or disable the display of camera number in the split-screen mode.
FULL ID	Enable or disable the display of camera identification in the full-screen or full-screen switching modes.
REC ID	Enable or disable the display of camera identification in VCR recording.
REC TIME	Enable or disable the display of the date and time in VCR recording.

System Clock

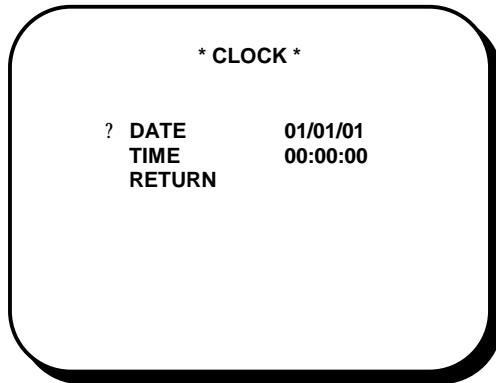

Setting the Current Date and Time

1. Select CLOCK from the MAIN MENU.
2. Using the ? ? or ? ? button to move the cursor to the DATE or TIME whose setting is to be changed. The ? ? and ? ? buttons are the SPLIT/SW and FREEZE buttons, respectively, while the MP/BMP400 is in user setup mode.
3. Select the item using the ENTER button. The ENTER button is the same as the PLAYBACK button when the MP/BMP400 is in user setup mode.
4. The currently selected field will blink.
5. Press the ? ? or ? ? button to change the value.
6. Confirm the setting by pressing the ENTER button. The cursor will automatically advance to the next field.
7. Repeat steps 4 and 5 until the last field is reached.

The new settings will be saved, and they will take effect when the last field is entered.

Camera ID

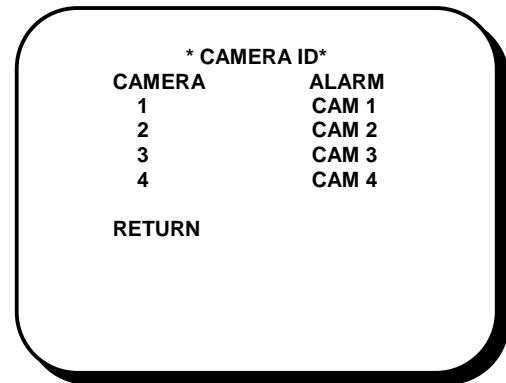

The MP/BMP400 provides up to seven characters for camera identification.

Changing the Camera ID

1. Select CAMERA ID from the MAIN MENU.
2. Using ? ? or ? ? button to move the cursor to the camera whose identification is to be changed. The ? ? and ? ? buttons are the SPLIT/SW and FREEZE buttons, respectively, while the MP/BMP400 is in user setup mode.
3. Select the desired camera using the ENTER button. The ENTER button is the same as the PLAYBACK button when the MP/BMP400 is in user setup mode.
4. The currently selected field will blink.
5. Press the ? ? or ? ? button to change the character.
6. Confirm the settings by pressing the ENTER button. The cursor will automatically advance to the next field.
7. Repeat steps five and six until the last field is reached.

The new settings will be saved and will take effect when the last field is entered.

Options

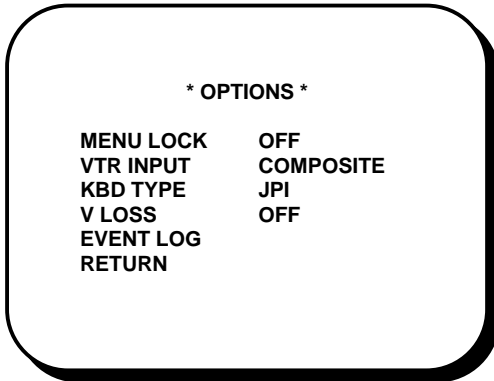

Menu Lock

Menu Lock allows you to lock the MAIN MENU. Once the menu is locked, the system password must be used to access the MAIN MENU.

Note: The MP/BMP400 has a pre-selected password: **1224**.

To access the locked MAIN MENU, enter the system password using the numbers on the buttons normally used for camera selection.

VTR Input

Select the input and output type of the VCR or time-lapse recorder. This can be set to S-video or composite.

KBD TYPE

Select the key pad input device, JPI or others (contact JPI).

V Loss

Select the type of alarm to be sounded in case of loss of video, OFF, BEEP or V-B.

Event Log

Reset or review event log.

Event Log

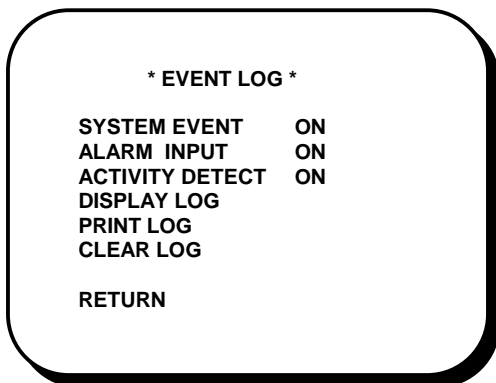

System Event

When enabled, the times when the system is turned on and off and when the menu is accesses are recorded in the log.

Alarm Input

When enabled, alarms triggered by the external alarm inputs are recorded in the log.

Activity Detect

When enabled, alarms triggered by activity detection are recorded in the log.

Display Log

Display event log on screen. Use the \leftarrow and \rightarrow buttons to scroll. The \leftarrow and \rightarrow buttons are the SPLIT/SW and FREEZE buttons, respectively, while the MP/BMP400 is in user setup mode.

Print Log

Use RS232 I/F to print log.

Clear Log

Clear all events in the log.

The event log is capable of recording up to 256 events. Once 256 events are reached, the oldest log entry is overwritten when new events are logged.

Factory Default Reset

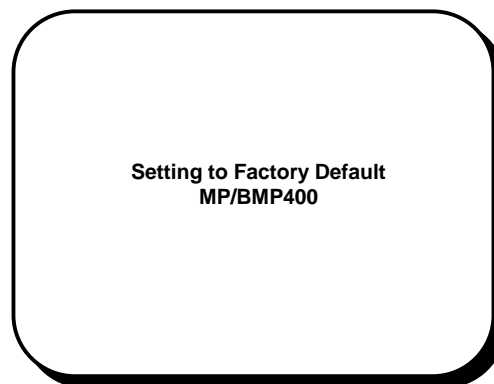

Resetting System Values to Factory Defaults

1. Move the cursor to FACTORY DEFAULT in the MAIN MENU.
2. Select FACTORY DEFAULT by pressing the ENTER button. The ENTER button is the same as the PLAYBACK button when the MP/BMP400 is in user setup mode.
3. The menu screen will disappear momentarily and then reappear. When this is complete, the factory default settings are restored.

Date, time and event log settings will not be affected by execution of factory default.

VCR Playback

PLAYBACK Button

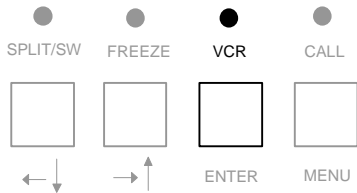

VCR Playback Mode

Enabling VCR Playback

Press the PLAYBACK button from any video mode. The VCR input (VCR IN) will be displayed on the main monitor. The VCR output will remain unchanged.

Returning to Live Mode

Press the PLAYBACK button in VCR playback mode. The mode prior to VCR playback mode will be restored.

Note: The MENU button in VCR playback mode will select a VCR bypass (see p.28) or a VCR tracking adjustment (see p. 29).

Full-Screen Mode Video Selector

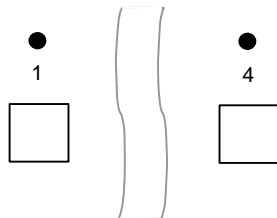

Full-Screen Mode

To select a desired camera input to be displayed, press the button number corresponding to the camera's number. For example, press button 2 to display the input from camera 2 on the main monitor.

Split-Screen Selector

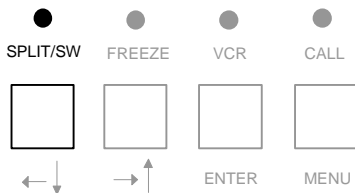

Split-Screen Mode

Press the SPLIT/SW button for less than three seconds from any full-screen or split screen mode.

Bypass Mode

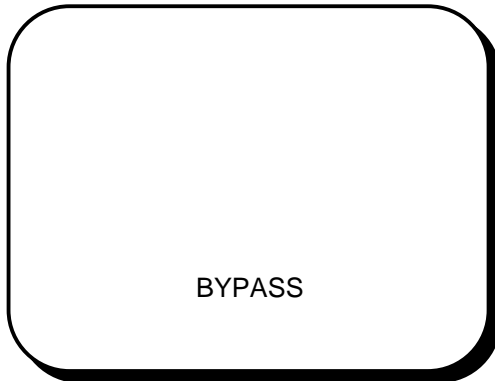

The MP/BMP400 has a unique feature that allows the monitoring of VCR input without de-multiplexing. This feature is useful for verifying correct operation of VCR output on the MP/BMP400 and for diagnosing VCR playback related problems.

Entering Bypass Mode

1. While in VCR playback mode, press the CALL button for less than three seconds. The word "BYPASS" will appear on the bottom of the screen.
2. There are three bypass modes: interlaced mode, odd only mode, and even only mode.
3. Each press of the MENU button will change the mode to the next mode and will return to the normal VCR playback mode after the last bypass mode.

Monitoring VCR Recording

By entering VCR bypass mode, the actual video images being recorded by the MP/BMP400 can be monitored. Due to the fact that the MP/BMP400 records all 4 camera at once by switching rapidly from one camera to the next, the video images displayed in this mode may not be recognizable. This is normal.

Diagnosing VCR Playback Problems

Most VCR playback problems arise because of improper system installation or because of VCR problems. By entering VCR bypass mode, the video images recorded by the VCR can be observed.

VCR Menu Setup

The video signal generated by VCR in the VCR setup menu may not be recognized by the de-multiplexing circuitry of MP/BMP400. To view video produced by the VCR setup menu, use VCR bypass mode.

Tracking Adjustment

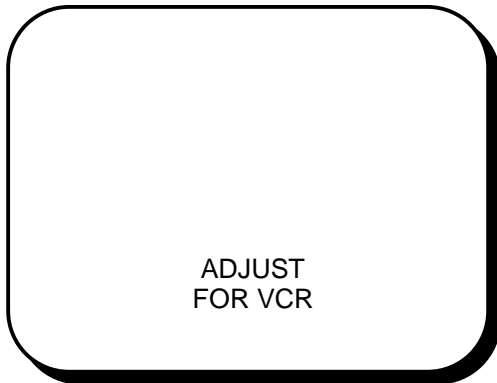

The MP/BMP400 allows you to enhance the tracking capabilities of certain VCRs that do not conform to standard video.

Entering Tracking Adjustment

Press the MENU button from any VCR playback mode. "ADJUST FOR VCR" will appear on the bottom of screen adjustment mode.

Enhancing the Tracking

1. Using the ? ? or ? ? button to adjust the tracking while the MP/BMP400 is in user setup mode.
2. Confirm the settings by pressing the ENTER button.
3. Press EXIT button to exit VCR tracking adjustment mode.

The new setting will be saved and take effect immediately.

Tip: If you see a line or noise between screens during play back, use the ? ? or ? ? button while in the VCR TRACKING ADJUSTMENT mode to adjust the tracking and line up the screens. This will insure the best possible playback quality.

Alarm Setup

Alarm Setup and Installation

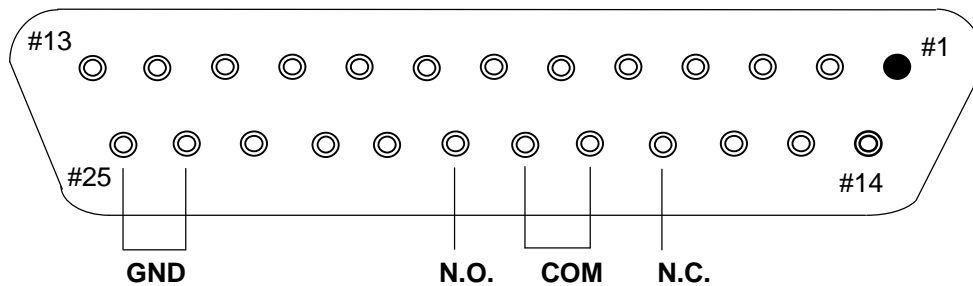

The MP/BMP400 provides an interface to external alarm inputs and outputs through a 25-pin D-SUB connector on the rear panel. Authorized dealers supply a mating connector to this for the MP/BMP400.

Pin Definitions

- 1 to 4** Alarm inputs for each corresponding camera. Each alarm can be either a normally open or a normally closed type. The alarm input type is automatically detected by the MP/BMP400.
- GND** Ground. Should be connected to the ground reference of the alarm detection device.
- N.O.** Normally Open alarm output. This can be connected to a VCR or time-lapse-recorder alarm input that requires a normally open alarm input.
- N.C.** Normally Closed alarm output. This can be connected to VCR or time-lapse recorder alarm input that requires normally closed alarm input.
- COM** Common alarm output. This can be connected to a VCR or time-lapse recorder alarm common port.

Alarm Setup

Typical Alarm Configuration Diagram

Alarm Input Type

The MP/BMP400's innovative design allows it to auto-detect the alarm input type; therefore, either a normally open or normally closed type of alarm device can be used with the MP/BMP400.

Note: Because the type of alarm is detected whenever the MP/BMP400 is powered on, make sure all the alarm inputs are normal - not triggered when the MP/BMP400 is powered on.

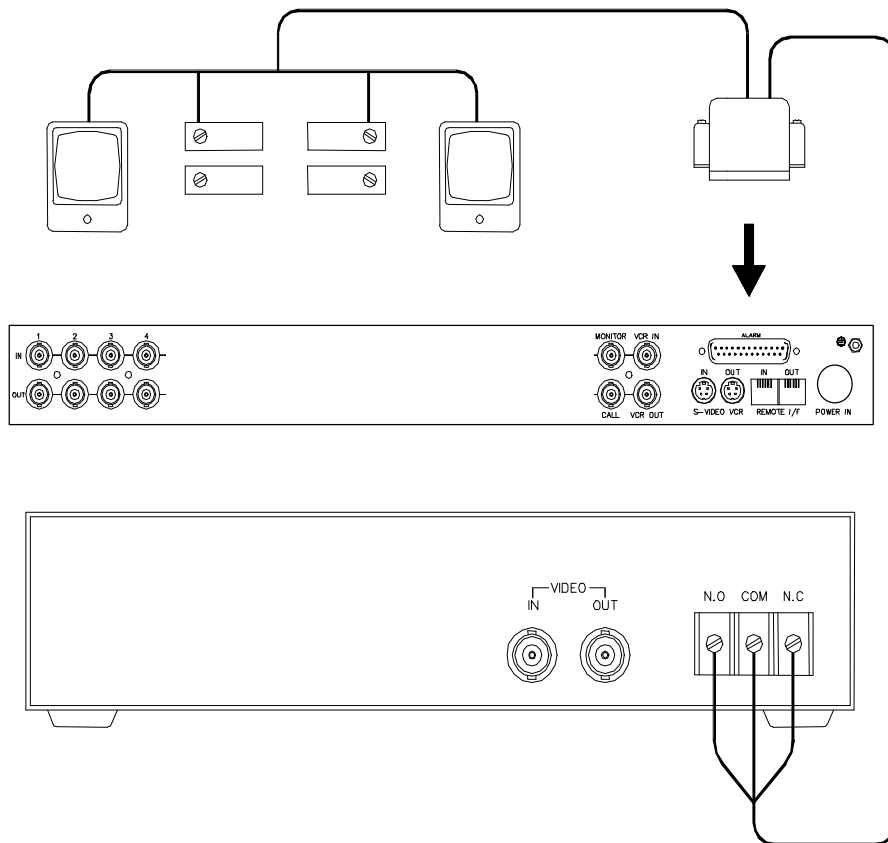

Remote I/F

Remote Interface Diagram

The MP/BMP400's remote interface allows the remote control of MP/BMP400 with a standard 6-conductor cable that is terminated with a 6-conductor RJ45 cables. With its use of the industry standard RS232 protocol, the MP/BMP400 can be interfaced to any system that supports RS232 interface, although optional software is required.

Interfacing with PC compatible RS232 ports.

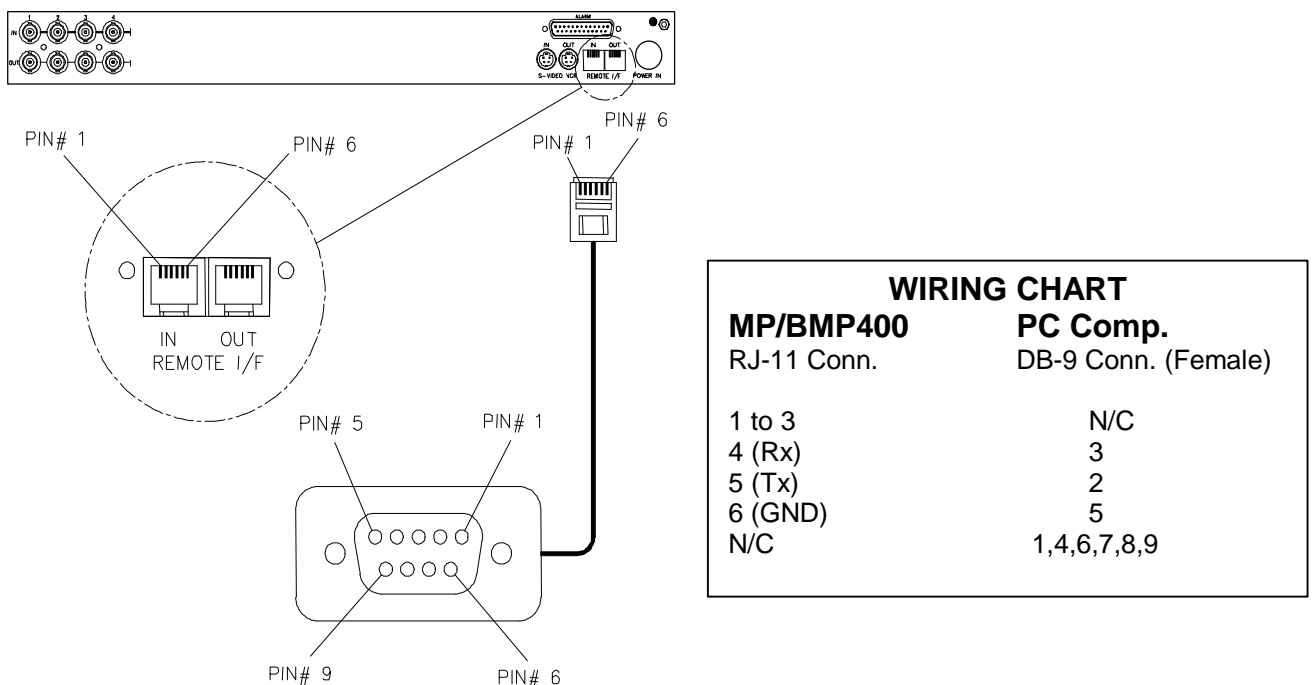

RS232 Interface Setup

Baud rate : 1200 bps
 Parity : None
 No of Bits : 8
 No of Stop bits : 1

MP/BMP400 Series Remote Interface Command Set

Command Set			Command Set		
Main Code	Secondary Code	Functions	Main Code	Secondary Code	Functions
a	0 1	Set Main Monitor output to CAM1	A	. 0 1	Set Call Monitor output to CAM1
b	0 2	Set Main Monitor output to CAM2	B	. 0 2	Set Call Monitor output to CAM2
c	0 3	Set Main Monitor output to CAM3	C	. 0 3	Set Call Monitor output to CAM3
d	0 4	Set Main Monitor output to CAM4	D	. 0 4	Set Call Monitor output to CAM4
/		- Set to Split Screen Mode (Cursor Down in Menu Mode)			
*	?	- Set/Reset Freeze Mode (Cursor Up in Menu Mode)			
-		- Toggle Live/VCR Modes (Select in Menu Mode)			
+		- Enter/Exit Menu Setup Mode			
V a		- Set to Live Mode			
V b		- Set to VCR Mode			
v d		- Split Screen Mode			
v e		- Sequence Mode			

Specifications

Video Inputs

Video Standards Signals

Video Inputs
VCR Input

NTSC or PAL (depending on model)

Composite, 1.0 V P-P, 75 ohms terminated (16-channels)
Composite, 1.0 V P-P, 75 ohms terminated
Components, S-Video Standards, 75 ohms terminated

Video Outputs

Video Standards Signals

Loop-back
Call Monitor

Main Monitor
VCR Output

NTSC or PAL (depending on model)

Active, Composite, approx. 95% of input signal
Active, Composite, approx. 95% of input signal
(*not a roll-free switching output*)
Composite, 1.0 V P-P
Composite, 1.0 V P-P
Components, S-Video Standards (Y-C)

Video Processing

Video Formats

Video Decoding
& Encoding

Video Processing

Main Monitor
VCR Output

NTSC CCIR601 (858x525 native res.)
PAL CCIR601 (864x625 native res.)
Fully Digital
8 channel parallel processing
4 channel semi-parallel processing

Onscreen Display

Camera Identification Date/Time

User selectable, 12-characters per camera
5 date formats, 3 time formats

Switcher Dwell Time

Individually controlled (0-59 sec per camera)
Roll-free switching

Alarm Processing

Inputs Outputs

NO/NC Auto-detection (at power-on)
Normally Open and Normally Closed
1.0A Max @ 24 V Resistive
or 0.25A Max @ 120/240 VAC Resistive

Remote Interface

RS232 Standard, RJ45
Proprietary pinout

Power

System AC Adapter

6A @5V Max
90-264 VAC, 50-60Hz, 1.7A Max

Dimension

17"(w) x 13" (d) x 1.75" (h)

* Specifications are subject to change without notice.